

A	B	C (mm)			D
1	S605-0001	1204	648	15	6/7
2	S605-0002	1204	648	15	7/7
3	S605-0003	1204	648	15	6/7
4	S605-0004	1204	254	16	7/7
5	S605-1001	2250	551	15	1/7
6	S605-1002	2250	580	15	2/7
7	S605-1003	2250	535	18	1/7
8	S605-3001	1176	535	15	3/7
9	S605-3002	1176	535	15	3/7
10	S605-3003	1176	480	22	4/7
11	S605-4001	1176	51	15	3/7
12	S605-4002	1176	51	15	3/7
13	S605-9301	2178	1185	3	2/7
14	dr-1171	1171	30	15	3/7

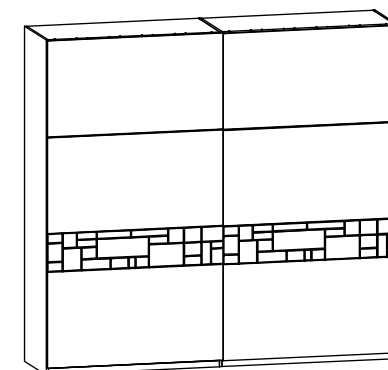



D
3/7, 5/7

cm

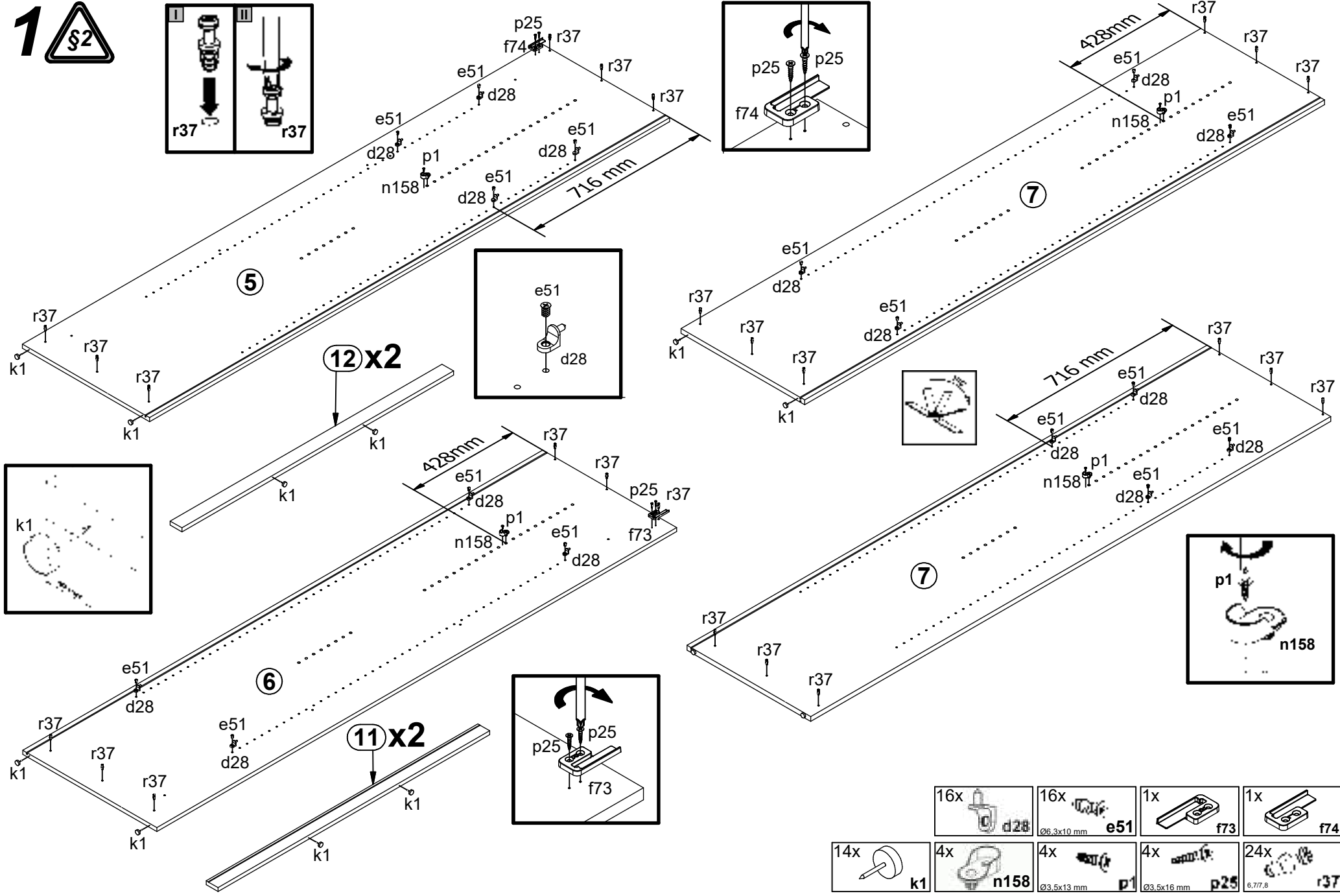
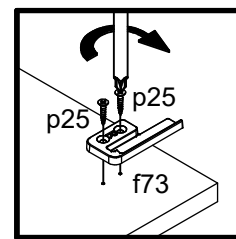
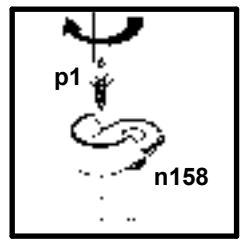
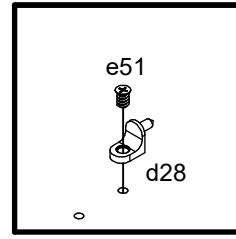
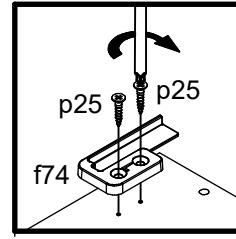
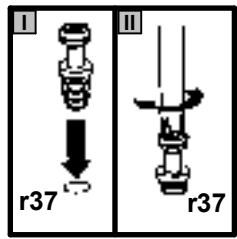
1 

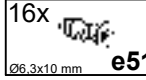
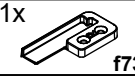
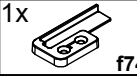
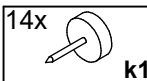

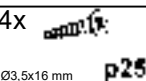
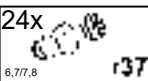
16x  r37	16x  e51 Ø6.3x10 mm	1x  f73	1x  f74
14x  k1	4x  n158	4x  p1 Ø3.5x13 mm	4x  p25 Ø3.5x16 mm
			24x  r37 6.7/7.8

2 

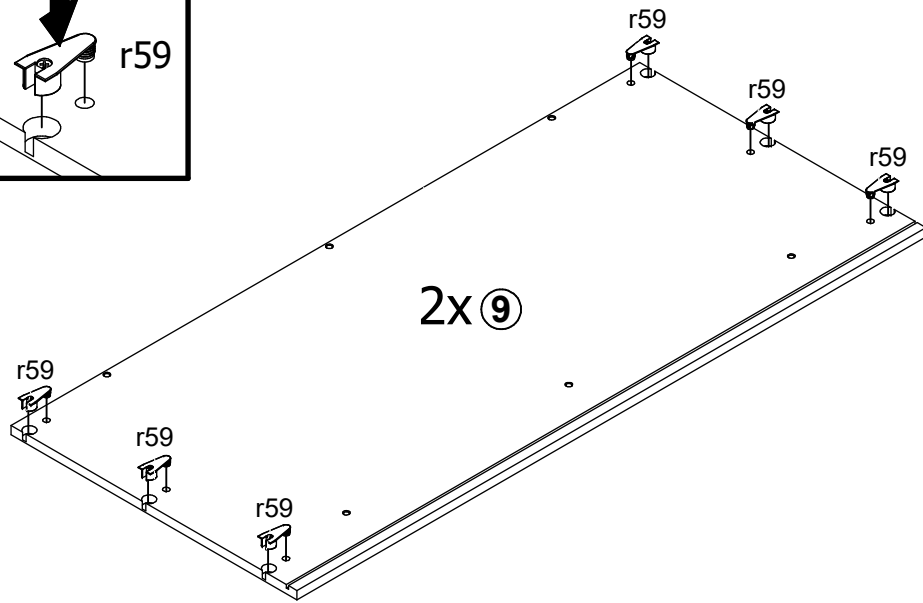
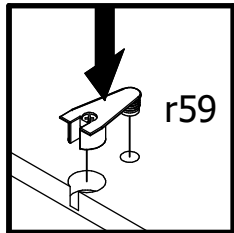
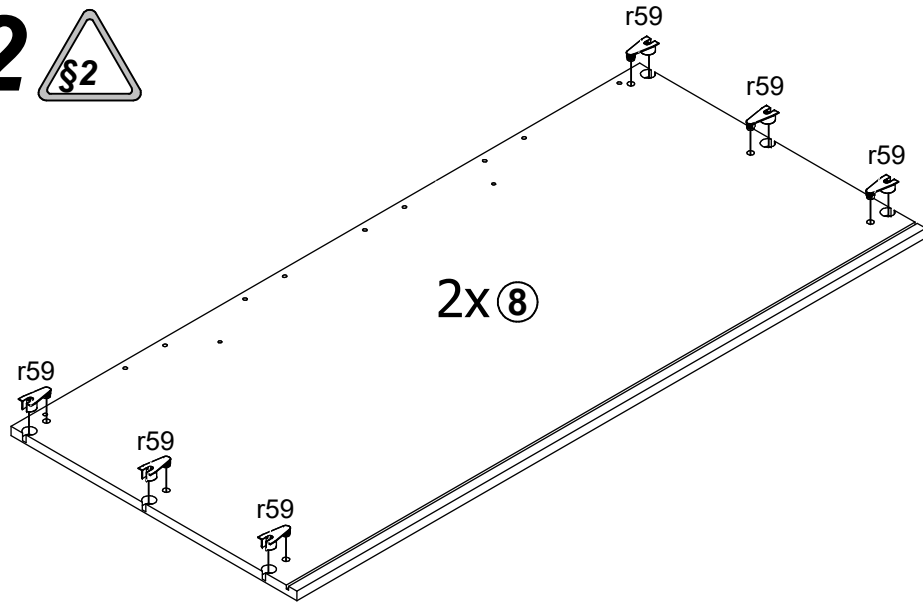

24x  #16
metal
Ø20x12,5 mm r59

3 

2x

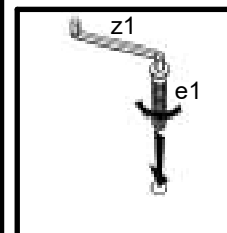
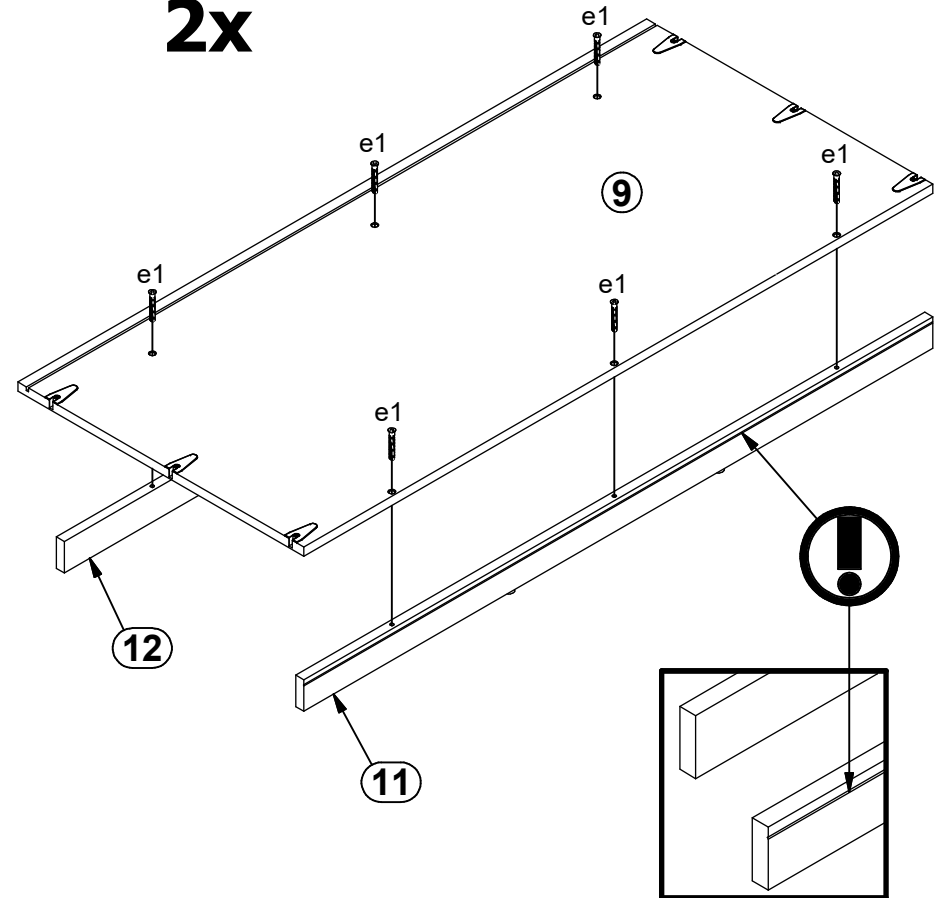

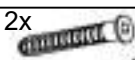
12x 
Ø7x50 mm e1

5

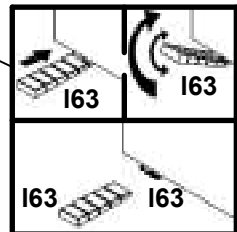
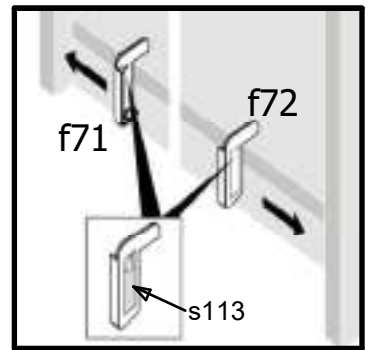
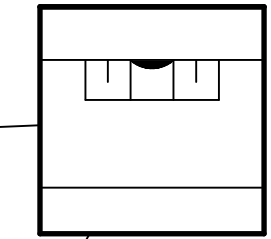
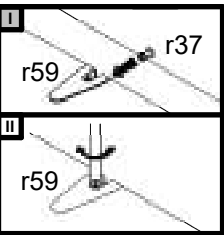
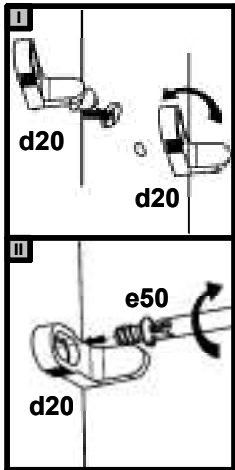
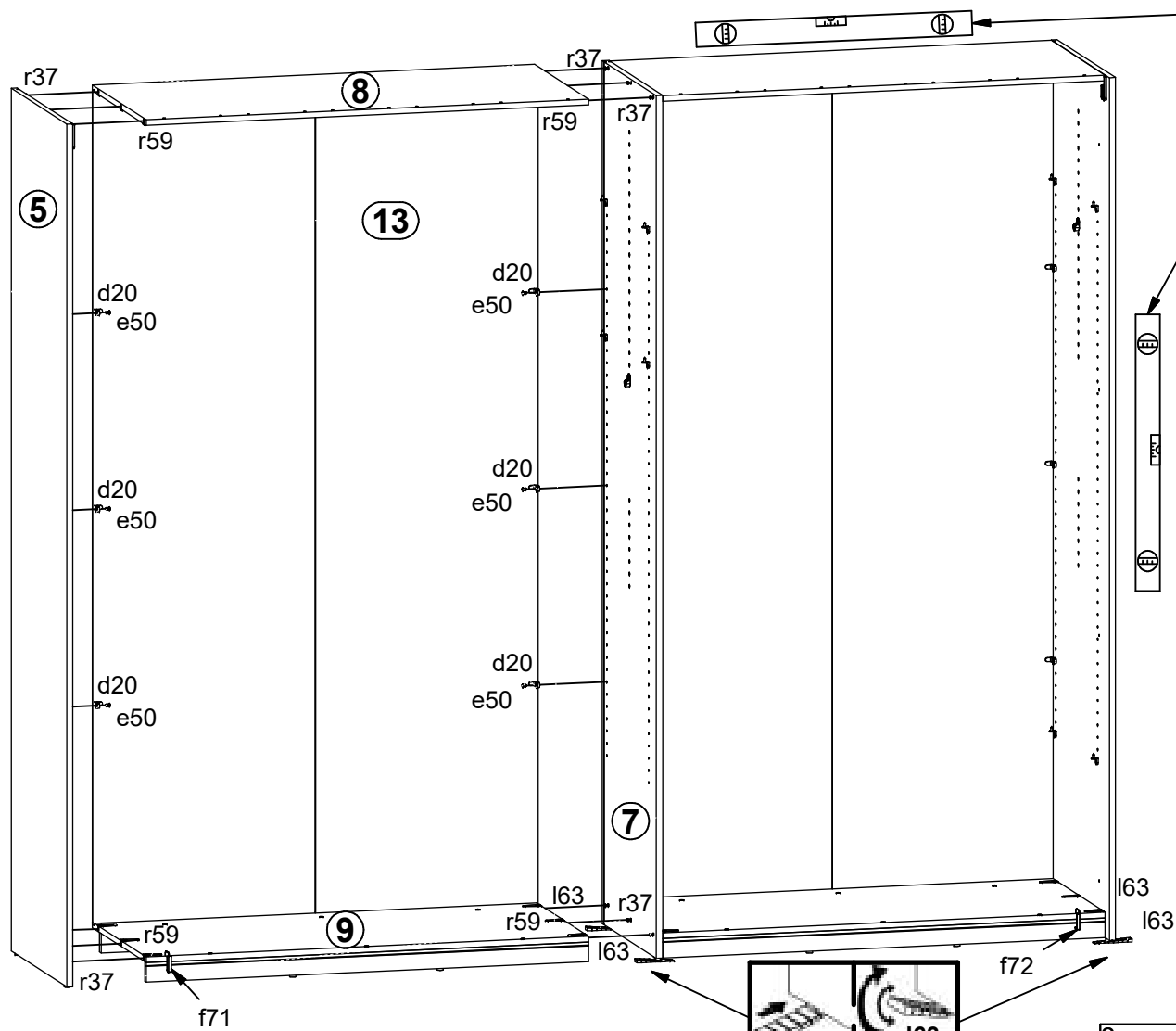

2x 35x9 mm s113	1x f71	1x f72
4x l63	6x d20	6x e50 Ø6.3x10 mm

6 

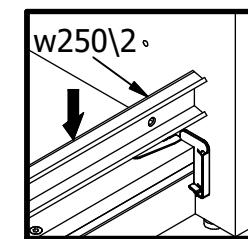
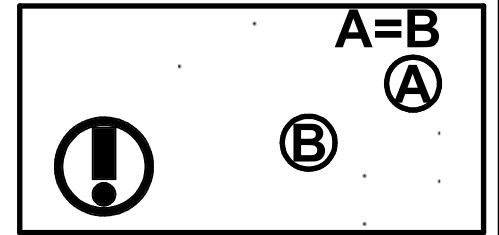
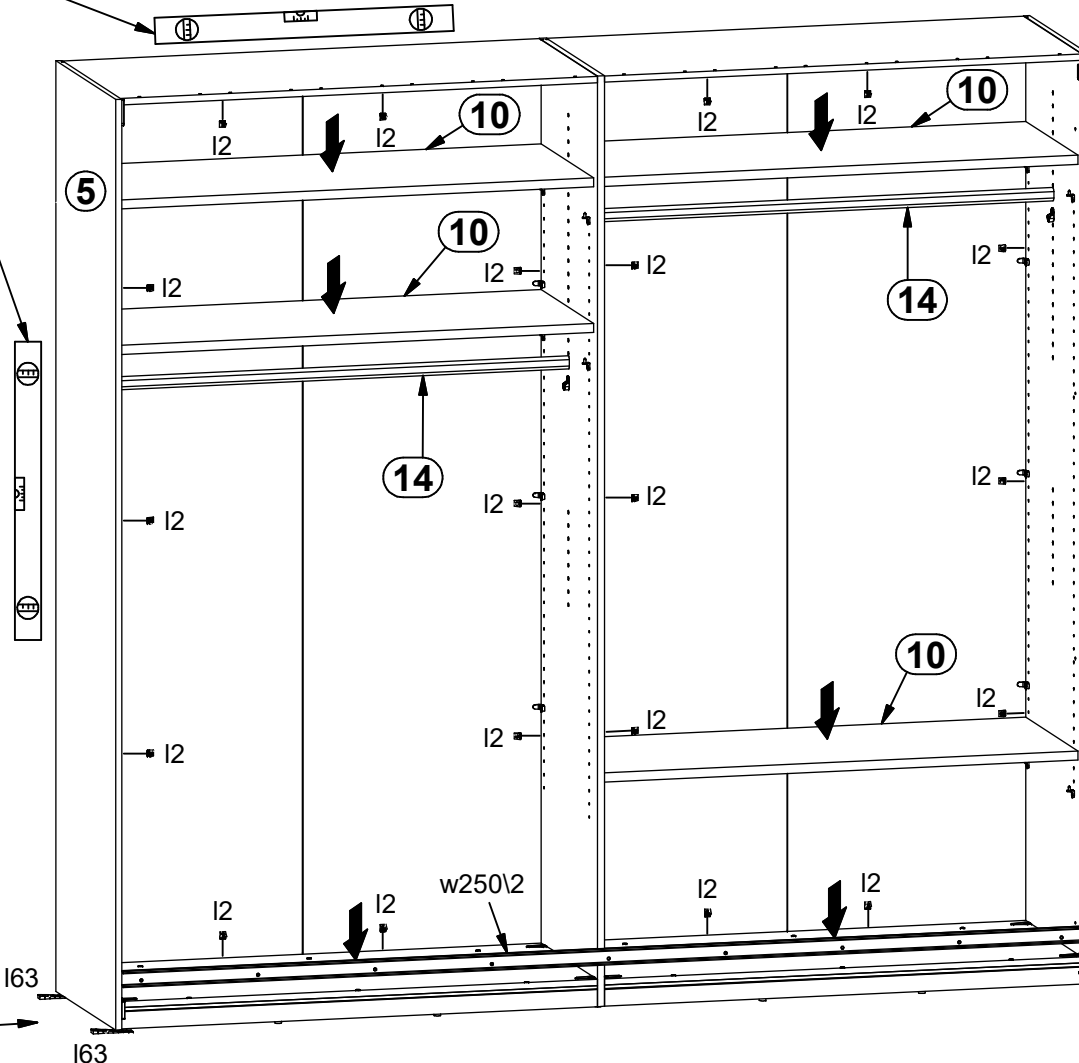
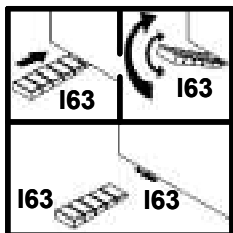
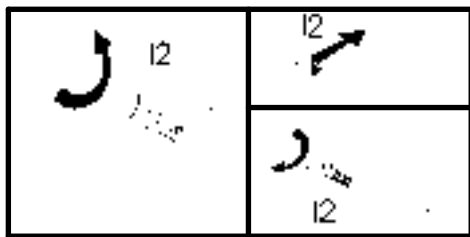
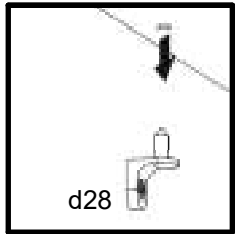
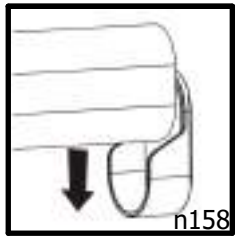
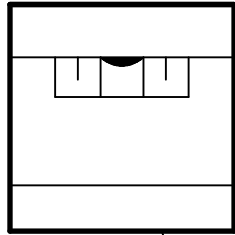

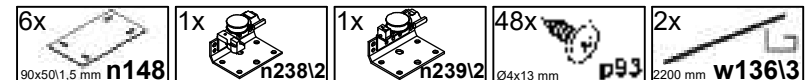
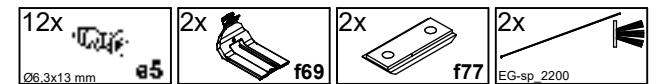
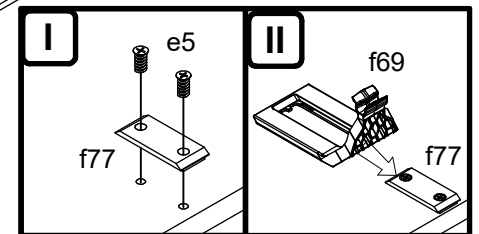
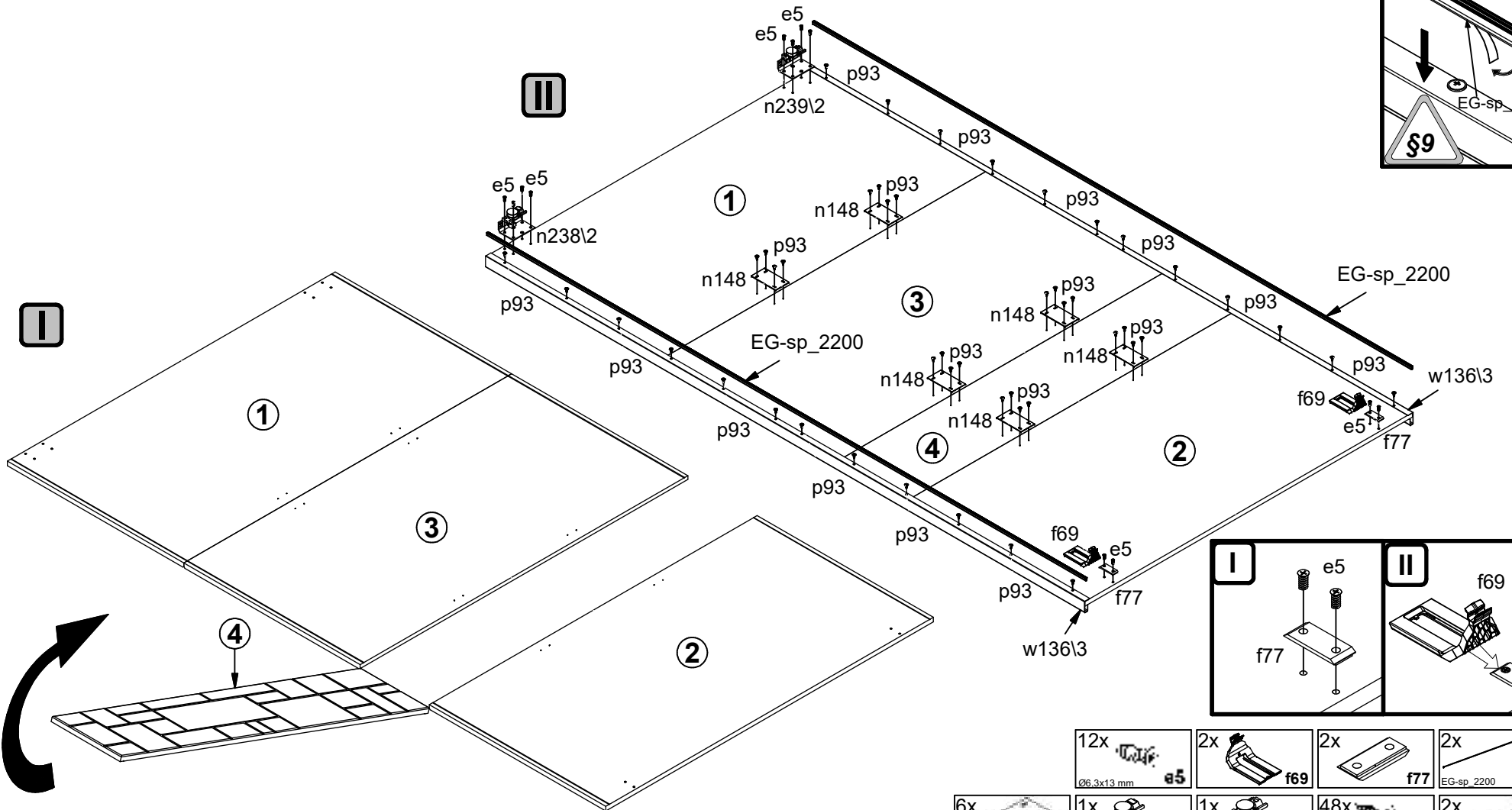
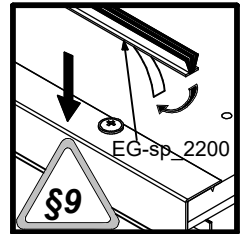
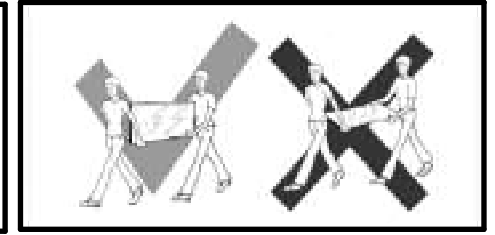
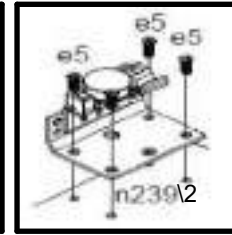
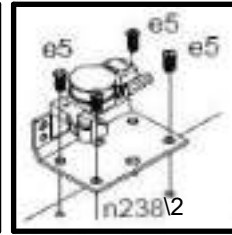
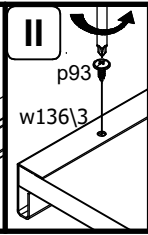
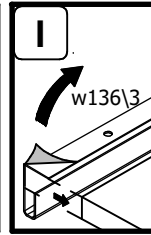
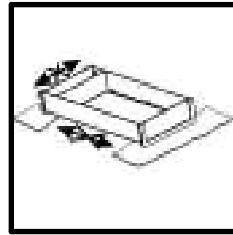

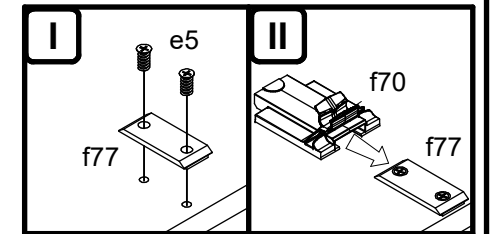
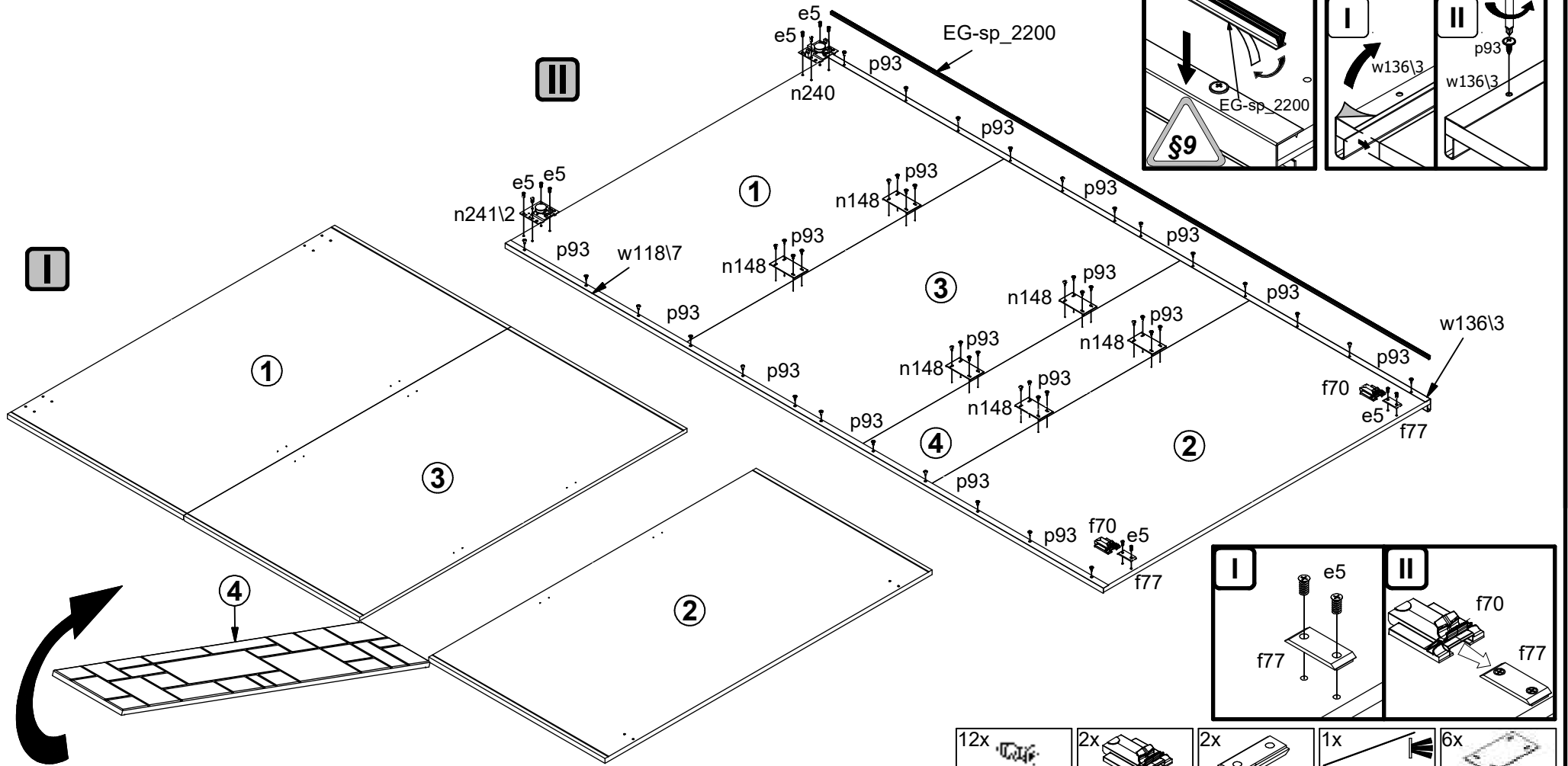
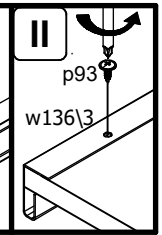
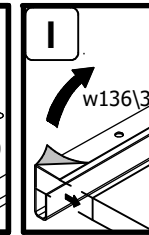
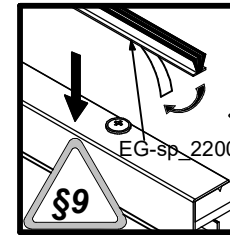
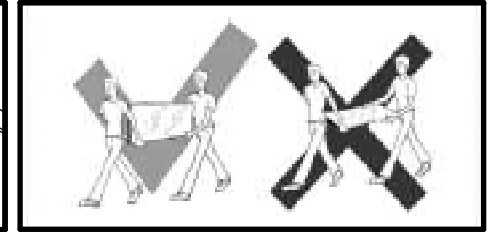
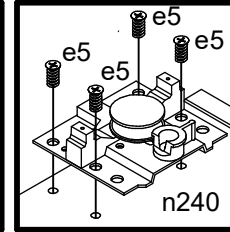
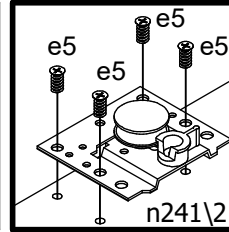
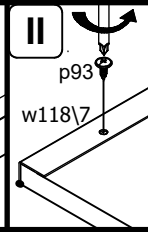
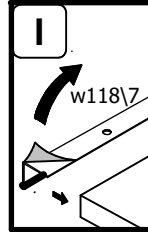
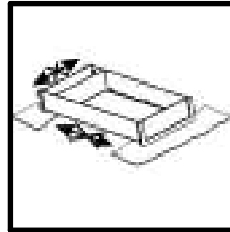

12x Ø6.3x13 mm e5	2x f70	2x f77	1x EG-sp_2200	6x 90x50\1.5 mm n148
1x n240	1x n241\2	48x Ø4x13 mm p93	1x 2200 mm w118\7	1x 2200 mm w136\3

10

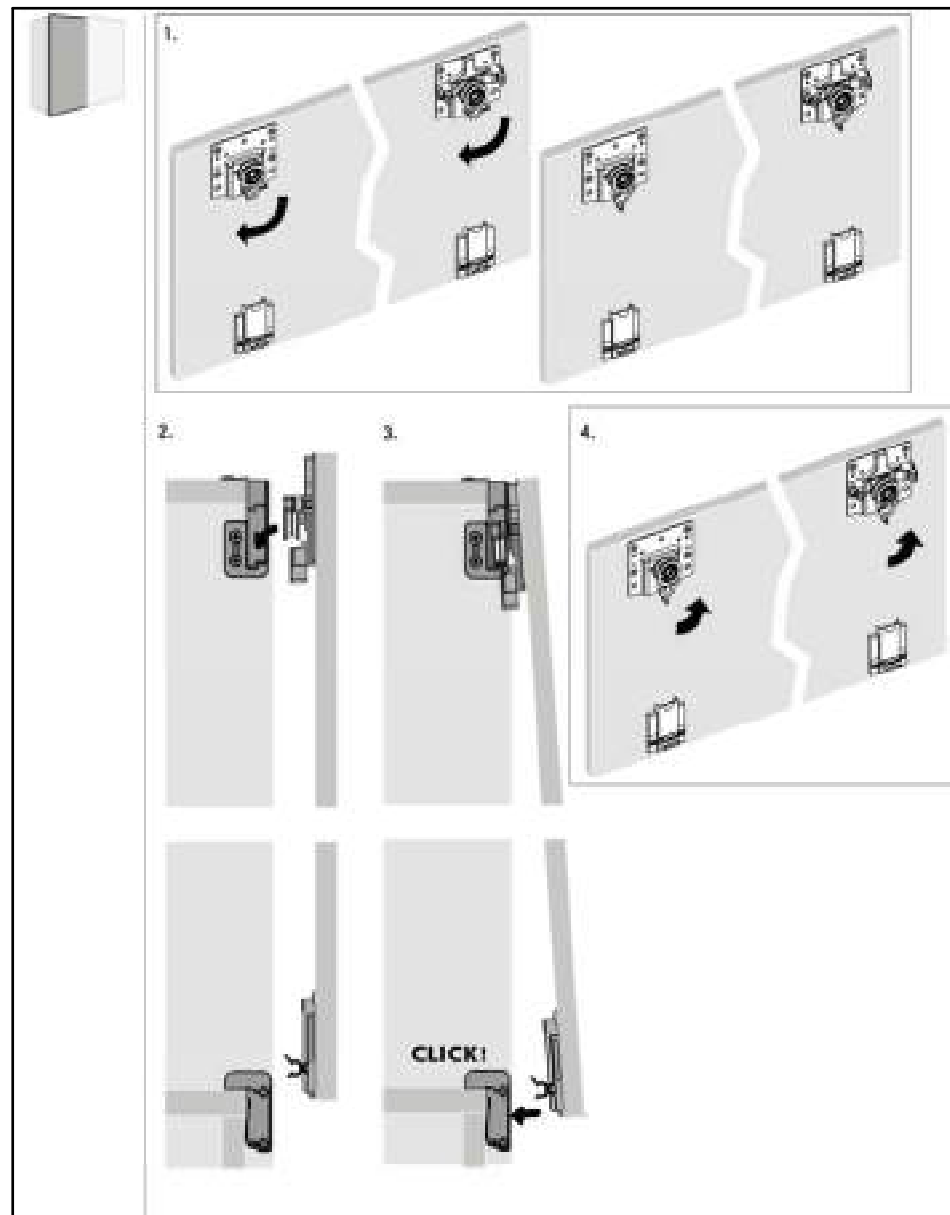
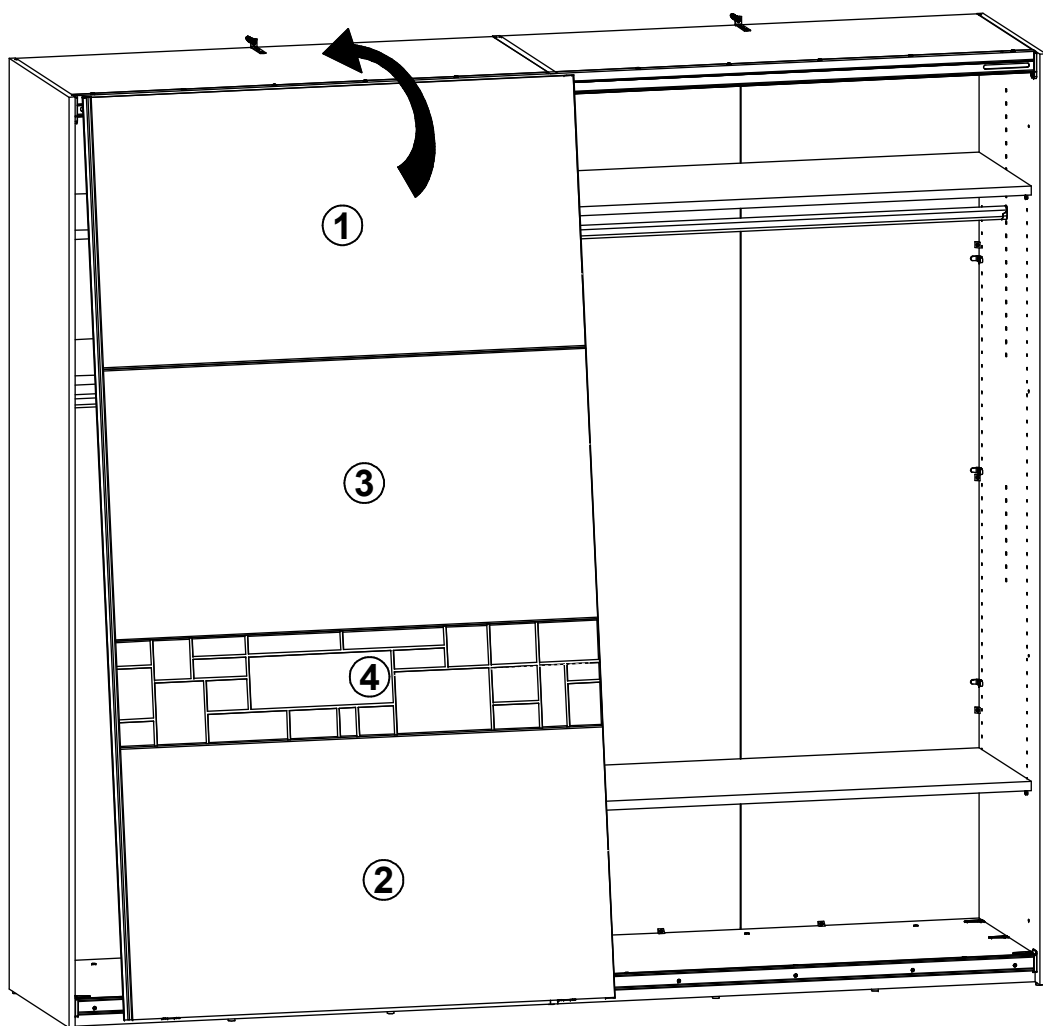

11

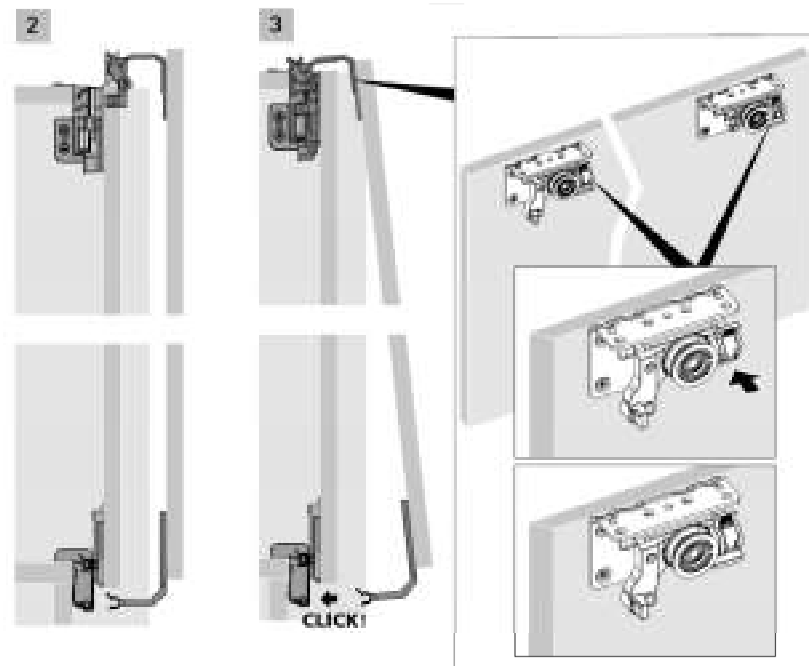
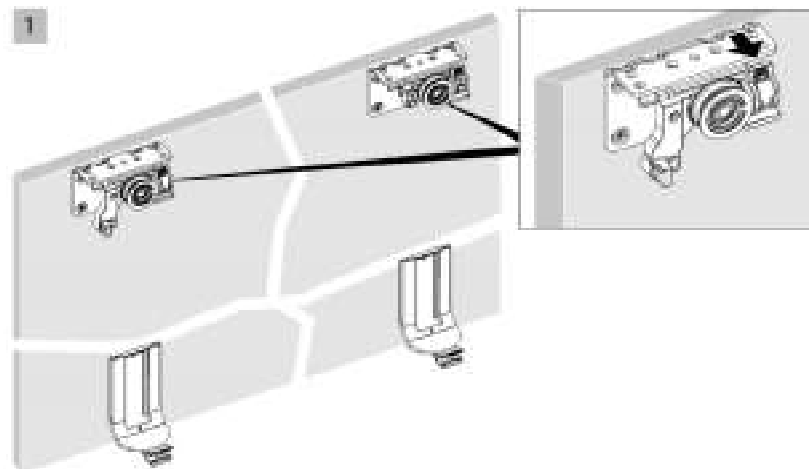
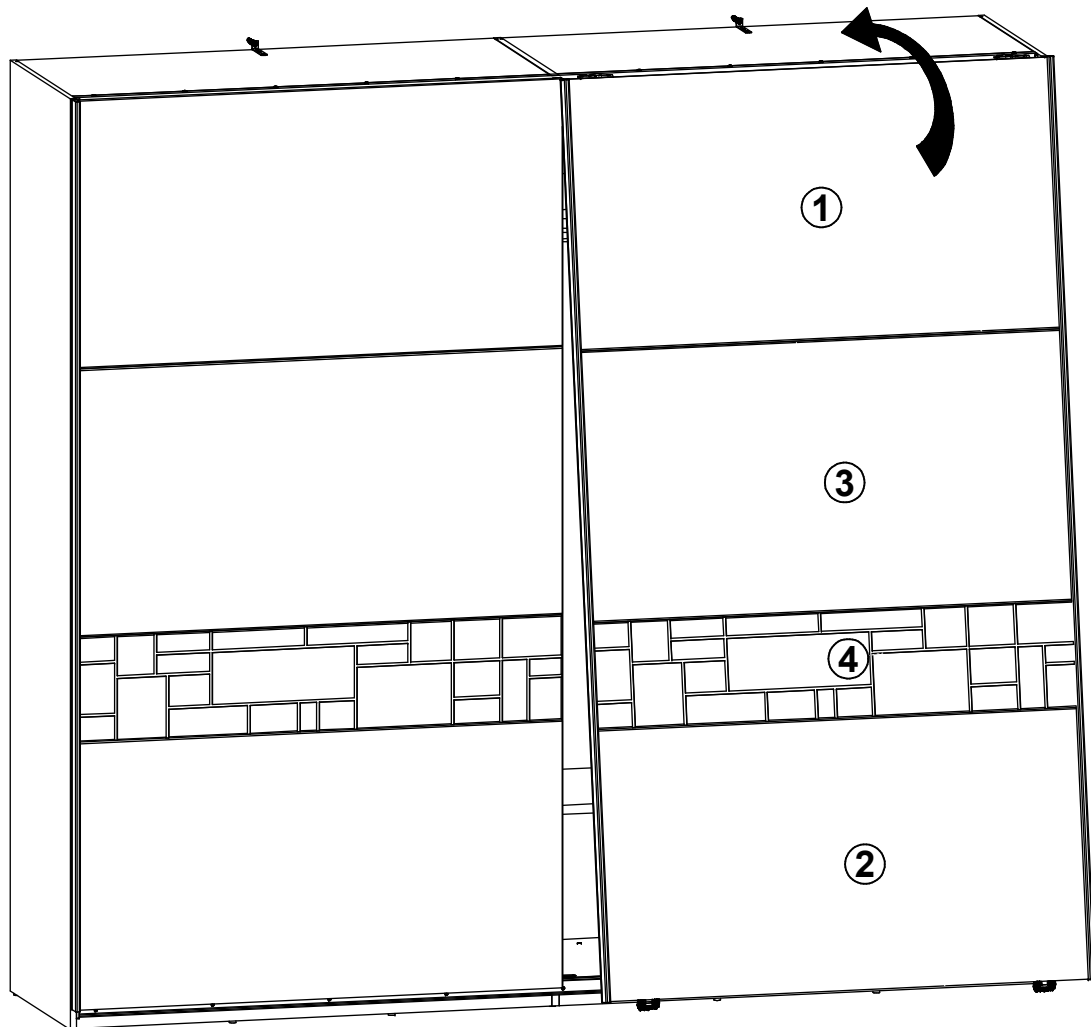

12

